

RC5513

RAPPER™ Family – 4 Watt Stereo Sound Driver

Features

- Up to 4W/channel
- Drives 8Ω and 4Ω non-powered speakers
- NO-POP during power-up/power-down and mute
- Provides regulated 5V supply for sound codec, etc.
- Line Output signal to noise ratio of 85 dB
- Microphone amplifier and AGC dynamic range of 40dB
- Microphone multiplexing
- Internal thermal limiting circuitry
- 24 Lead SOIC package
- Total Harmonic Distortion < 0.1%

Applications

- Multimedia PC motherboards and add-in sound cards
- Companion chip to Sigma-Delta Sound Codecs
- Sound Channel back-end in Set-top boxes

Description

The Rapper is a stereo sound driver used for driving key functions that are needed in all multimedia PCs and sound cards. These functions include directly powering speakers

and headphone sets, providing a microphone pre-amplifier with AGC, and having a 12V to 5V regulator that can isolate the noise from the sound channel.

Block Diagram

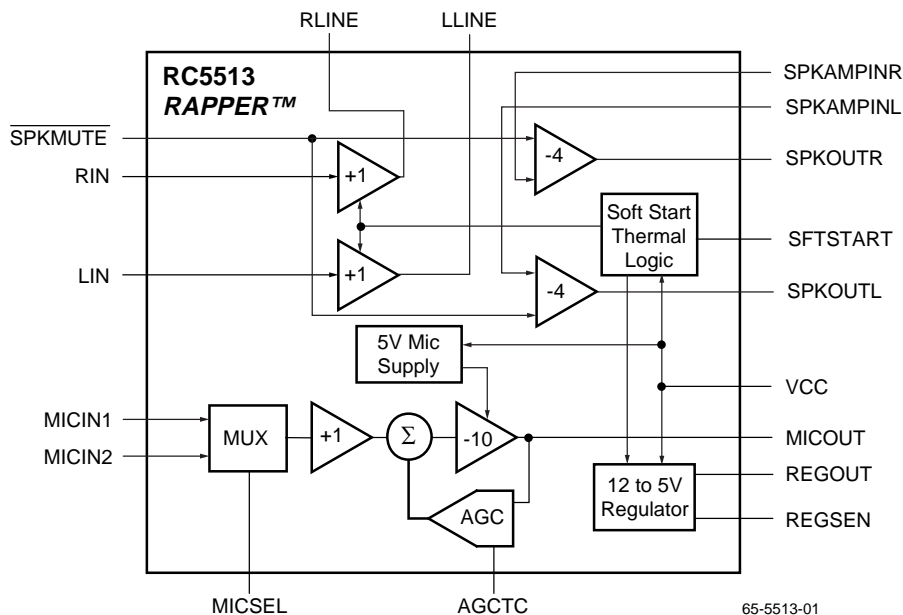

Preliminary Information

Functional Description

The Rapper Stereo Sound Driver is an audio device that can be used on PC motherboards and add-in sound cards. It consists of stereo output drivers for headphone or speakers, a low noise microphone amplifier with AGC, and a regulator to provide a clean 5V supply.

The output drivers can deliver up to 2 Watts peak and 4 Watts peak into 8Ω and 4Ω speakers, respectively, from a 12V source. The drivers use class AB amplifiers and maintain a low bias current. To help prevent popping signals a delay is provided to these output drivers to allow settling. The time constant is user-defined through an external capacitor (CDELAY) on the SFTSTART pin.

The microphone amplifier feeds into an AGC with a dynamic range of 40dB. An external capacitor is used to provide

attack and decay features. Attack and decay times can be varied linearly by varying an external capacitor (CAD) on the AGCTC pin. The attack and decay time ratio has been set for pleasant audio quality.

The 12 V to 5V voltage regulator can provide up to 20mA of current without external components. It can provide a clean regulated voltage supply to the other devices that complete the sound channel. Use of an external transistor can boost the regulator output to 150mA or higher with the appropriate thermal precautions. The line regulation of 50dB improves the cross talk and the power supply rejection ratio of all other audio blocks that are supplied by the 5V source.

The thermal limiting circuitry activates if the chip temperature typically exceeds 150°C.

Pin Assignments

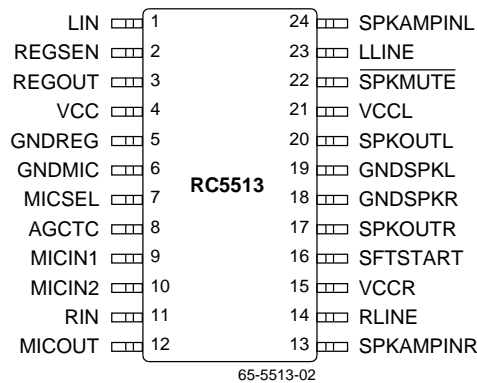

Preliminary Information

Pin Definitions

Pin Name	Pin Number	Pin Function Description
LIN	1	Left Channel Input
REGSEN	2	Regulator Sense Point
REGOUT	3	Regulator 5V Output
VCC	4	12V Power Supply Input
GNDREG	5	Regulator Ground
GNDMIC	6	Microphone Ground
MICSEL	7	MICOUT Select. LOW selects MICIN1, HIGH selects MICIN2
AGCTC	8	Attack and Decay Capacitor Pin
MICIN1	9	Microphone Input 1
MICIN2	10	Microphone Input 2
RIN	11	Right Channel Input
MICOUT	12	Microphone Output
SPKAMPINR	13	Right Channel Power Amplifier Input
RLINE	14	Right Line Driver Output
VCCR	15	Right Speaker Supply
SFTSTART	16	Soft Start Timing Capacitor
SPKOUTR	17	Right Speaker Output
GNDSPKR	18	Right Speaker Ground
GNDSPKL	19	Left Speaker Ground
SPKOUTL	20	Left Speaker Output
VCCL	21	Left Speaker Supply
SPKMUTE	22	Speaker Mute
LLINE	23	Left Line Driver Output
SPKAMPINL	24	Left Channel Power Amplifier Input

Absolute Maximum Ratings

(beyond which the device may be damaged)¹

Parameter		Min	Typ	Max	Units
VCC	Power supply voltage			13.2	V

Note:

- Functional operation under any of these conditions is NOT implied. Performance is guaranteed only if Operating Conditions are not exceeded.

Operating Conditions

Parameter		Conditions	Min	Typ	Max	Units
VCC VCCR VCCL	Power Supply		11.2	12	12.8	V
V _{IH}	Input Voltage Logic High		2			V
V _{IL}	Input Voltage Logic Low				0.8	V
	Ambient Temperature		0		70	°C
T _c	Maximum Operation Die Temperature	Overthermal Protection		150		°C
I _{total}	Power Supply Current	No load		19	25	mA
ESD	ESD Threshold	Human Body Model	2000			V

Electrical Characteristics

VCC = 12V ± 6%, unless otherwise specified.

Parameter		Conditions	Min	Typ	Max	Units
Line Driver		f = 1KHz, RL = 600Ω unless otherwise specified				
Z _{in}	Input Impedance			10		KΩ
A _v	Voltage Gain	V _{in} = 1 V _{rms}	0.95	1.0	1.05	V/V
L&R A _v	Left and Right Gain Matching	V _{out} = 4V _{P-P}		0.3		%
V _o	Output Voltage	RL = 600Ω		±4		V
THD	Total Harmonic Distortion	V _{out} = 4V _{P-P}		0.01		%
PSRR	Power Supply Rejection Ratio	f = 100Hz, ΔV _{cc} = 0.85V _{rms}	80	86		dB
SNR	Signal to Noise Ratio	V _{in} = 2.8V _{rms}		85		dB
Speaker Driver		f = 1KHz, RL = 8Ω unless otherwise specified				
I _{spk}	Speaker Driver Supply Current	V _{in} = 0V		5		mA
Z _{in}	Input Impedance		100			KΩ
A _v	Voltage Gain	V _{in} = 0.5 V _{rms}	3.80	-4.0	-4.20	V/V
L&R A _v	Left and Right Gain Matching	V _{out} = 4V _{P-P}		0.5		%
V _o	Output Voltage	RL = 4Ω or 8Ω, VCC = 12V		±4		V
SNR	Signal to Noise Ratio	Input Referenced		85		dB
P _o	Power Output Per Channel Peak	RL = 4Ω, VCC = 12V (See Figure 1)		4		W

Preliminary Information

Electrical Characteristics (continued)V_{CC} = 12V ± 6%, unless otherwise specified.

Parameter		Conditions	Min	Typ	Max	Units
CS	Channel Separation L/R Input Referenced	V _{in} = 0.5 V _{rms}	66			dB
XTALK	Cross Talk L/R to Mic Input Referenced	V _{in} = 1 mV _{rms}	90			dB
XTALK	Cross Talk L/R to Reg Input Referenced	V _{in} = 0.5 V _{rms}	75			dB
THD	Total Harmonic Distortion	f _o = 1KHz, P _o = 50mW		0.1		%
Noise		20Hz to 20kHz, A-Weighted		4		μV _{rms}
PSRR	Power Supply Rejection Ratio Input Referenced	f = 100Hz, ΔV _{cc} = 1.6V _{p-p}	70	80		dB
Microphone Amplifier		f = 1KHz, R _L = 10KΩ unless otherwise specified				
I _{micamp}	Microphone Amp Supply Current	V _{in} = 0V, max gain		4		mA
Z _{in1}	First Amp Input Impedance			4.5		KΩ
A _{v1}	First Amp Gain			1		V/V
A _{v2}	Second Amp Gain			-10		V/V
AGC	AGC Dynamic Range			40		dB
THD	Total Harmonic Distortion	V _{in} = 5mV _{p-p} , AGC off		0.1		%
Noise		20Hz to 20kHz, A-Weighted		8		μV _{rms}
XTALK	XTALK from other blocks at MICOUT	V _{in} = 1V _{rms} at 1KHz	70			dB
PSRR	Input Referenced	f = 100Hz, ΔV _{cc} = 1.6V _{p-p}	70			dB
Voltage Regulator						
I _{reg}	Voltage Regulator Supply Current			1.5		mA
V _{reg}	Regulator Voltage		4.75	5	5.25	V
T _c	Tempco			0.5		mV/°C
	Line Regulation			3		mV/V
	Load Regulation			2		mV/mA
I _o	Output Current	Source		20		mA
		Source With External 2N2222		150		mA
		Sink		100		μA
Soft Start						
Delay	Anti-Pop Ramp-Up and Ramp-Down time	No Pop condition C _{DELAY} = 22μF on SFTSTART		2		sec

Applications Discussion

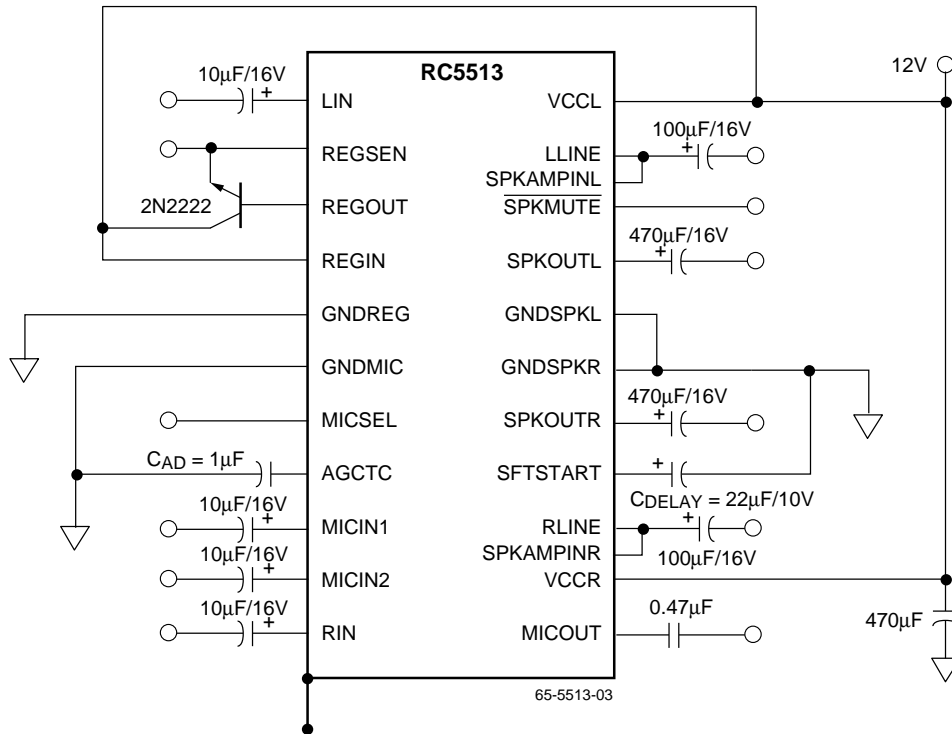

Notes:

1. 4 watt power represents the peak of the audio level and cannot be sustained without correct package thermal considerations. The average audio signal can be sustained by the RC5513 without extra thermal considerations.
2. To improve the thermal resistance of the SOIC package a heat sink can be used.

Figure 1. Rapper™ RC5513, 4 Ohm Speaker, 4 Watt Application with External Pass Transistor for Voltage Regulator

Preliminary Information

Mechanical Dimensions – 24 Lead SOIC Package

Symbol	Inches		Millimeters		Notes
	Min.	Max.	Min.	Max.	
A	.093	.104	2.35	2.65	
A1	.004	.012	0.10	0.30	
B	.013	.020	0.33	0.51	
C	.009	.013	0.23	0.32	5
D	.599	.614	15.20	15.60	2
E	.290	.299	7.36	7.60	2
e	.050 BSC		1.27 BSC		
H	.394	.419	10.00	10.65	
h	.010	.020	0.25	0.51	
L	.016	.050	0.40	1.27	3
N	24		24		6
α	0°	8°	0°	8°	
ccc	—	.004	—	0.10	

Notes:

1. Dimensioning and tolerancing per ANSI Y14.5M-1982.
2. "D" and "E" do not include mold flash. Mold flash or protrusions shall not exceed .010 inch (0.25mm).
3. "L" is the length of terminal for soldering to a substrate.
4. Terminal numbers are shown for reference only.
5. "C" dimension does not include solder finish thickness.
6. Symbol "N" is the maximum number of terminals.

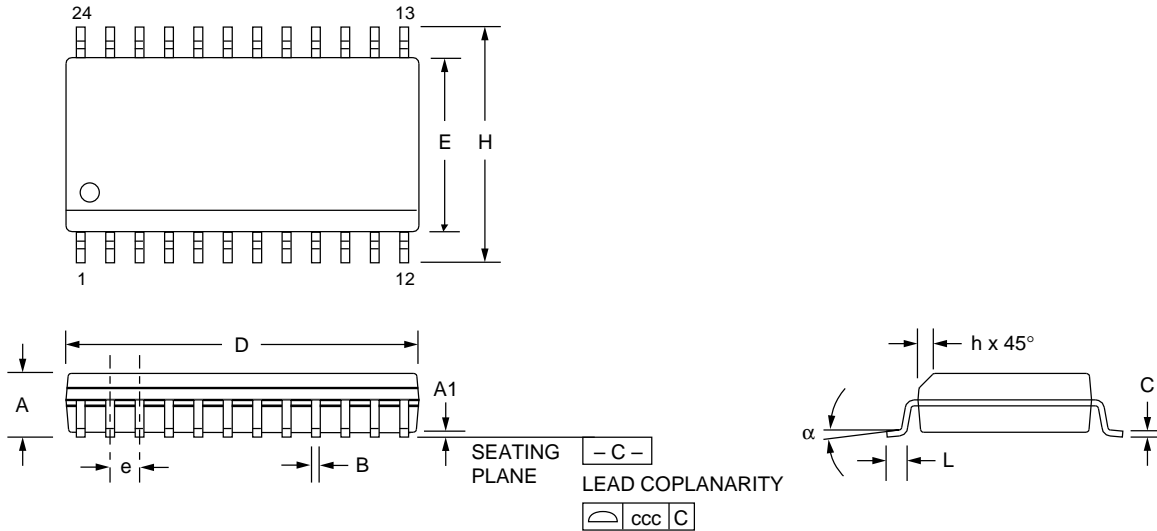

Preliminary Information

Ordering Information

Product Number	Package
RC5513M	24 SOIC

Preliminary Information

The information contained in this data sheet has been carefully compiled; however, it shall not by implication or otherwise become part of the terms and conditions of any subsequent sale. Raytheon's liability shall be determined solely by its standard terms and conditions of sale. No representation as to application or use or that the circuits are either licensed or free from patent infringement is intended or implied. Raytheon reserves the right to change the circuitry and any other data at any time without notice and assumes no liability for errors.

LIFE SUPPORT POLICY:

Raytheon's products are not designed for use in life support applications, wherein a failure or malfunction of the component can reasonably be expected to result in personal injury. The user of Raytheon components in life support applications assumes all risk of such use and indemnifies Raytheon Company against all damages.

Raytheon Electronics
Semiconductor Division
350 Ellis Street
Mountain View CA 94043
415 968 9211
FAX 415 966 7742